

## DEVELOPMENT AND SUBSTANTIATION OF ROCK UNLOADING DEVICE WITH THROUGH-PASSING OF TRUCKS

<sup>1</sup>S.K. Moldabayev✉, <sup>2</sup>A.A. Adamchuk, <sup>1</sup>N.O. Sarybayev, <sup>1</sup>A.S. Moldabayev, <sup>1</sup>A.N. Nurmanova

<sup>1</sup>Satbayev University, Almaty, Kazakhstan,

<sup>2</sup>Dnipro University of Technology, Dnipro, Ukraine,

✉Corresponding author: s.moldabayev@satbayev.university

Different types of constructions of transshipment devices for combined schemes of automobile-conveyor transport are analyzed. A device of a new design was developed based on the identified shortcomings of known devices. The efficiency of the rock unloading device with through-passing trucks has been checked for the conditions of iron-ore mines in Kazakhstan.

New device works because of rock weight force, which rotates bridges, that cover bunker for truck to move above it. Rotating bridges makes it possible to move rock down to bunker. After that, bridges close because of counterweight, which is a fence at the same time.

The efficiency criteria of rock unloading device is volume reduction of mining capital works. Parameters were considered: width of the open-cast mine at the top and bottom, design depth of the mine, load capacity, turning radius and width of trucks, as well as the cost of extracting 1 m<sup>3</sup> of rock.

The dependence of reducing the costs of conducting mining capital works in deep open-cast mines during the construction of a transshipment point of combined automobile-conveyor transport with a through passage when unloading trucks from their carrying capacity have been established.

**Keywords:** combined automobile-conveyor transport, through-passing trucks, rock unloading device, mining capital works.

## РАЗРАБОТКА И ОБОСНОВАНИЕ УСТРОЙСТВА РАЗГРУЗКИ СКАЛЬНОЙ ПОРОДЫ АВТОСАМОСВАЛАМИ СО СКВОЗНЫМ ПРОЕЗДОМ

<sup>1</sup>С.К. Молдабаев✉, <sup>2</sup>А.А. Адамчук, <sup>1</sup>Н.О. Сарыбаев, <sup>1</sup>А.С. Молдабаев, <sup>1</sup>А.Н. Нурманова

<sup>1</sup>Сатпаев Университет, Алматы, Казахстан,

<sup>2</sup>Национальный технический университет «Днепро́вская политехника», Днепр, Украина,

e-mail: s.moldabayev@satbayev.university

Проанализированы различные типы конструкций перегрузочных устройств для комбинированных схем автомобильно-конвейерного транспорта. Устройство новой конструкции разработано с учетом выявленных недостатков известных устройств. Работоспособность устройства разгрузки скальной породы автосамосвалами со сквозным проездом проверена в условиях железорудных карьеров Казахстана.

Новое устройство работает за счет силы веса горной породы, которая вращает мосты, закрывающие бункер, над которым может передвигаться грузовик. Вращающиеся мосты позволяют перемещать камни в бункер. После этого мосты закрываются из-за противовеса, который одновременно является ограждением.

Критерием эффективности устройства для разгрузки породы является сокращение объемов горно-капитальных работ. Учитывались параметры: ширина карьера поверху и понизу, проектная глубина котлована, грузоподъемность, радиус поворота и ширина самосвалов, а также стоимость добычи 1 м<sup>3</sup> горной массы.

Установлена зависимость снижения затрат на проведение горно-капитальных работ на глубоких карьерах при строительстве перегрузочного пункта комбинированного автомобильно-конвейерного транспорта со сквозным проездом при разгрузке самосвалов от их грузоподъемности.

**Ключевые слова:** комбинированный автомобильно-конвейерный транспорт, сквозной проезд автосамосвалов, устройство для разгрузки породы, горно-капитальные работы.

## ТОҚТАУСЫЗ ӨТЕТІН САМОСВАЛДАРМЕН ТАУ ЖЫНЫСТАРЫН ТҮСІРУГЕ АРНАЛҒАН ҚҰРЫЛҒЫНЫ ӨЗІРЛЕУ ЖӘНЕ НЕГІЗДЕУ

<sup>1</sup>С.К. Молдабаев✉, <sup>2</sup>А.А. Адамчук, <sup>1</sup>Н.О. Сарыбаев, <sup>1</sup>А.С. Молдабаев, <sup>1</sup>А.Н. Нурманова

<sup>1</sup>Сәтпаев Университеті, Алматы, Қазақстан,

<sup>2</sup>Ұлттық техникалық университет «Днепр политехникалық», Днепр, Украина,

e-mail: s.moldabayev@satbayev.university

Автомобиль-конвейер көлігінің құрама сұлбалары үшін қайта тиеу құрылғыларының конструкцияларының әртүрлі типтері талданды. Құрылғының жаңа дизайны белгілі құрылғылардың анықталған кемшіліктерін ескере отырып әзірленді. Қазақстандағы темір кені карьерлері жағдайында тоқтаусыз өтуі бар самосвалдармен тау жыныстарын түсіруге арналған құрылғының өнімділігі сыналды.

Жаңа құрылғы жүк көлігі қозғала алатын бункерді жабатын көпірлерді айналдыратын тау жынысының салмағының күші арқылы жұмыс істейді. Айналмалы көпірлер тастарды бункерге жылжытуға мүмкіндік береді. Осыдан кейін көпірлер қарсы салмаққа байланысты жабылады, бұл қоршау да болып табылады.

Тау жыныстарын түсіруге арналған құрылғының тиімділігінің критерийі тау-кен және құрылыс жұмыстарының көлемін азайту болып табылады. Сол үшін келесі параметрлер ескерілді: карьердің үстіңгі және төменгі жағындағы ені, карьердің жобалық тереңдігі, жүк көтергіштігі, бұрылу радиусы және самосвалдардың ені, сонымен қатар, тау-кен жұмыстарының құны 1 м<sup>3</sup> тау-жынысы массасынан.

Автосамосвалдардан жыныстарды түсіру кезінде тоқтаусыз өтуі бар құрама автомобиль-конвейерлік көлікті ауыстырып тиеу пунктін салу кезінде терең карьерлерде тау-кен және құрылыс жұмыстарын жүргізуге кететін шығындарды азайтудың олардың жүк көтергіштігіне тәуелділігі белгіленді.

**Түйін сөздер:** құрама автомобиль-конвейерлік көлік, автосамосвалдардың тоқтаусыз өтуі, тау жыныстарын түсіруге арналған құрылғы, тау-кен және құрылыс жұмыстары.

**Introduction.** In the conditions of iron ore open-cast mines, automobile-conveyor combined transport has become widespread, the essence of the schemes of which is that the rock is transported by truck from the pit to the concentration horizon, on which a bunker-transloader with a coarse crushing crusher is installed (Fig. 1) [1]. The truck unloads the rock into the bunker, which, after crushing, falls on an inclined conveyor installed in an underground gallery, which is

then transported to the surface.

Trucks are unloaded into the bunker as follows. When approaching the bunker, the truck reduces its speed and begins to perform dead-end maneuvering operations. Next, the truck reverses to the opening of the receiving bunker, stops and starts unloading. After unloading, the truck returns to the track and drives to be uploaded.

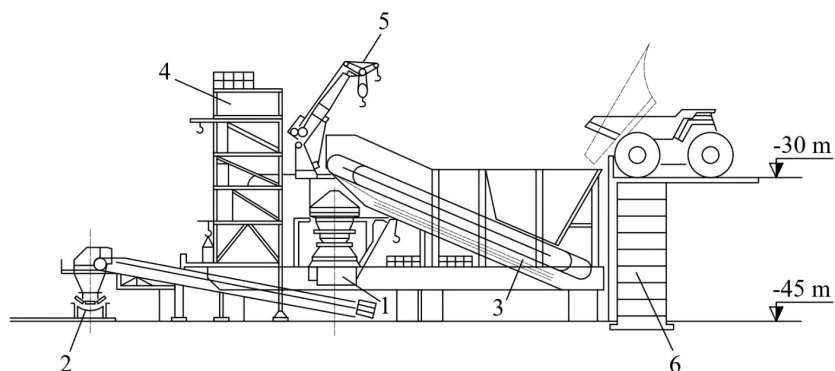

Figure 1 – Crushing and transshipment station with dead-end unloading of trucks into a bunker:

1 – crusher; 2 – steep belt conveyor; 3 – plate feeder; 4 – control panel; 5 – lifting crane; 6 – retaining wall [1]

To arrange a stationary transshipment point (STP), it is necessary to have a side of the mine, placed in the final position. The STP can be equipped with crushing and screening equipment and a bunker-accumulator. If there is no bunker-accumulator, a warehouse of rock should be placed near the STP with its overloading by an excavator or a wheel loader.

Trucks can be unloaded into the bunker both with a dead-end turn and through passing. Congestion can be predicted both on the lower horizon of the conveyor installation and on several concentration horizons. With dead-end unloading, the crusher, screen and bunker-accumulator can be located in the body of the ledge. Otherwise, it is necessary to provide for the presence of a plate feeder for feeding the rock to the crusher or overpasses for unloading trucks.

The purpose of research is to develop a new construction of rock unloading device with through-passing of trucks and to substantiate its effectiveness. The main tasks to achieve this purpose are: to analyze known reloading devices with a search for their shortcomings; develop a new design of device taking into account the identified shortcomings in known solutions; contrast it with known designs of transfer points and identify their shortcomings; select the criterion for the device effectiveness; substantiate the effectiveness of the device

**Materials and methods.** Despite the obvious advantages of unloading trucks with through passage, some constructive solutions have several significant disadvantages. A well-known device for unloading trucks into a bunker (Fig. 2), which contains a rotary bridge connected to the bunker by a hinge, a rigidly fixed counterweight on the rotary bridge, supports, pedals for interaction with the wheels of the unloaded truck, levers that actuate the rotary bridge, guides for the wheels of a truck and a conveyor [2].

The disadvantage of this device is the limited number of trucks that can simultaneously unload into the storage bunker, which reduces the productivity of the conveyor installation. In addition, opening the bridge takes approximately 10–15 seconds of the truck's operating time in intensive mode due to pressing the bridge opening lever. However, the biggest disadvantage is that there is a significant possibility of the truck coming off the lever after pressing it and closing the bunker cover. Re-entry of the truck in reverse for unloading is impossible due to the presence of the lever. Thus, when using this device, it is necessary to provide sufficiently wide platforms for the possibility of turning around trucks. Installation of a drive for lifting the bridge will increase the reliability of the device, but will require additional energy [3–6].

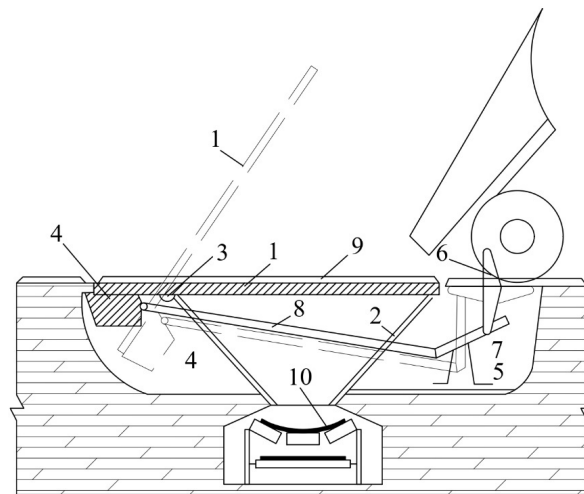

Figure 2 – Device for unloading trucks into a bunker with hinged and lever bridge lifting:

- 1–lifting bridge; 2 – bunker; 3 – hinge; 4 – counterweight; 5 – supports; 6 – pedals; 7,8–levers; 9 – guides; 10 – conveyor [4]

One of the well-known solutions is the use of a cross-moving bridge in the design of the transshipment device (Fig. 3). Its essence is that after passing over the bunker, the truck stops for unloading behind the bridge. After that, the bridge on rails or rollers moves away in the direction perpendicular to the axis of movement of the truck, then the truck unloads the rock, after which the

bridge is closed [7–9].

This design is much simpler than the previous one, however, an autonomous drive must be used to move the bridge, and the lid opening time is approximately 20–30 seconds. In addition, for the construction of a bunker of this design, an additional width of the platform for movement of the bridge must be provided.

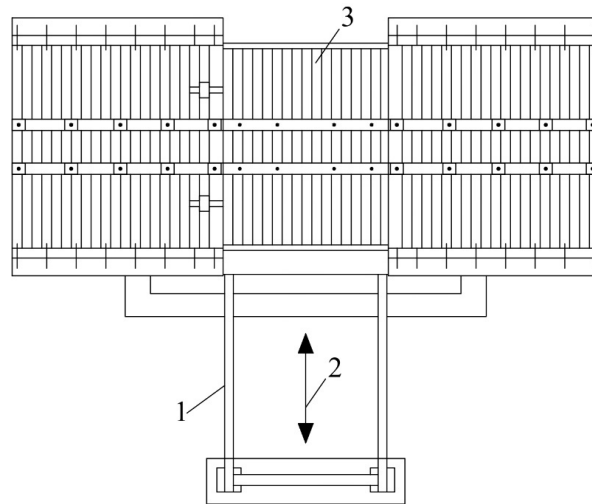

Figure 3 – Device for unloading trucks into a bunker with a cross-moving bridge:

1 – rails; 2–direction of movement of the cross-moving part of the bridge; 3 – the middle cross-moving part of the bridge [9]

There are also known transshipment points that include a rotating platform [10]. The principle of operation of such devices is as follows. A truck loaded with rock drives onto the rotary platform, after which it begins to turn around the vertical axis together with the truck so that the latter becomes at a right angle to the axis of movement for unloading into the bunker. After unloading the rock, the rotary platform returns the truck to its original position, which continues moving in the original direction.

The solution with a rotating platform allows you to significantly reduce the width of the platform in comparison with a transshipment point with dead-end unloading due to the reduction of the turning radius of the truck. However, the total turning time of the platform is over 60 seconds when the truck engine is idling, and the platform has a separate drive that uses additional energy to operate.

A number of designs of transshipment points with drive beams are known [11, 12]. Their work consists

in the fact that the loaded truck drives over the bunker on the turning beams, unloads on them, after which the beams rotate, due to which the rock from the surface of the beams enters the bunker.

Among all the considered solutions, the last one has the shortest unloading cycle time and the smallest platform width. However, the beam drive requires additional energy expenditure for their rotation. Also, the beams with which the truck moves must be of such a design that it can withstand the weight of the vehicle, the impact of the unloading rock, and at the same time correctly turn and return to the starting position. In addition, there is a danger of failure of the stoppers, which can cause the truck to go off the track.

In connection with the noted shortcomings of the known solutions for unloading rocks into a bunker with through-passage of trucks, in Dnipro University of Technology in cooperation with Satbayev University and JSC "Sokolovsk-Sarbaisky mining and processing industrial association" (JSC "SSMPIA") was proposed

a fundamentally new solution (Fig. 4), which differs in that after passing the truck, the rock is unloaded onto swing bridges, which are connected hinges with beams located perpendicularly, which move motor vehicles, while the counterweights serve as a barrier fence, located on both sides of the beams from the outer side of the passage and ensure the straight-line movement of trucks of the corresponding load capacity [13, 14].

To the reception point with the storage bunker 2, the truck 1 loaded with rock, along the reinforced concrete beams 4, enters for unloading between the

barrier fences-counterweights 6 on the swing bridge 3 and stops with the possibility of unloading on the nearest swing bridge 3, which is located behind the truck 1. After unloading the rock under the influence of its weight rotates the rotary bridges 3 in the horizontal plane around the hinges of rotation 5 with the resolution in the open position, and the rock falls into the storage bunker 2. Next, barrier fences-counterweights 6 under the influence of their weight return to their initial position and close the swing bridges 3, after which the cycle of unloading trucks 1 to the storage bunker 2 is repeated.

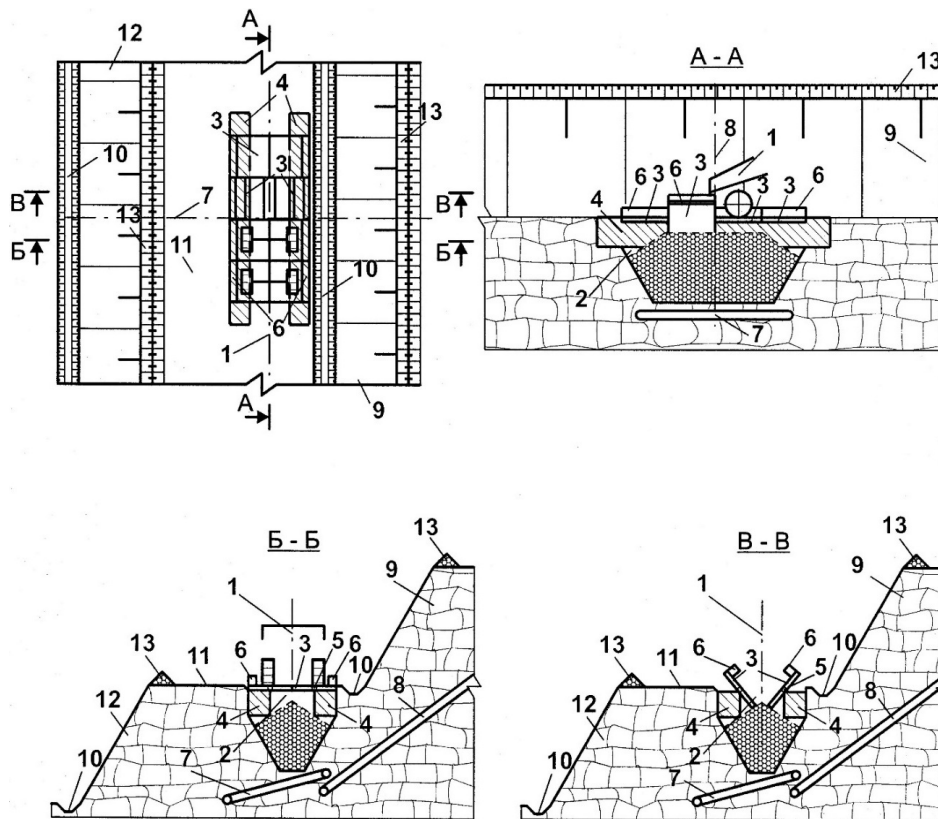

Figure 4 – A device for unloading rocks into a bunker with through-passage of trucks [14]

After the rock reaches the bunker, it is moved through the transfer conveyor 7 to the main conveyor 8 or the skip elevator, which transports the rock to the surface.

To prevent groundwater from entering the storage bunker 2, a drainage ditch 10 is constructed in the sole of the upper bench 9. To prevent trucks 1 and other moving equipment from falling from the platform for passing auxiliary equipment 11 to the lower bench 12,

a safety rock embankment 13 is erected on its upper edge.

The patent examiner opposed the device [15], when the truck is unloaded on the semi-chutes of the receiving pit, which lie on a concrete track with a flange and are fixed to it with the possibility of turning around the longitudinal axes. After unloading, the truck leaves the tracks and presses the wheels on the pedal, which activates a lever mechanism that rotates the semi-



---

chutes, due to which the track is cleaned.

It should be noted that lever systems cannot fully ensure the reliability and safety of the reloading device in the conditions of uneven cargo flows in open-pit mining operations. Large pieces of rock can damage the elements of the half-chutes rotation mechanism. The significant weight of heavy trucks inevitably leads to damage to the mechanism and cannot ensure a continuous process of unloading rocks into the bunker. In contrast to the opposite device, the rotation mechanism of the declared one is blocked by unloading bridges, is easy to install and operate, and the track cleaning process occurs independently of the action of the truck, due to the action of the weight of the rock.

In addition, when unloading the rock through the opposed device, the truck makes two stops: when unloading the rock and during track cleaning. This leads to an increase in the unloading cycle time and, as a result, a decrease in the throughput of the transshipment point. When unloading through the declared device, the truck makes only one stop to unload the rock.

The design of half-chutes in the opposite device has a complex profile, which increases their cost and complicates the process of their installation and operation. The claimed device provides another implementation as unloading bridges as metal plates with counterweights attached from the outside. Such a design can withstand dynamic loads from the impact of large pieces of rock and ensure a continuous process of unloading trucks regardless of the volume and composition of the load, and the rigid fastening of the barrier fence allows, in addition to the safety of the movement of trucks along the bridge, to turn the bridges due to their weight in starting position.

The construction of another opposing device [16] is as follows. The hinged-lever unloading system is attached to the framework of the overlapping track and consists of shields pivoting relative to the hinges, which are hingedly connected through levers and rods to the shield channels, which cover the tracks and are hinged to them from the inside. A fence consisting of channels and a wooden crossbar is installed along each track from the outside.

The opposite device works as follows. A truck loaded with rock drives along the track, stops, lifts the body and unloads. Under the influence of the weight of the cargo, the shields turn in the vertical plane, passing it into the bunker. After that, the overlapping shields return to their original position under the influence of the weight of the hinge-lever system elements.

The rotation of the unloading shields in the opposite device is brought about, as in the claimed invention, because of the weight of the cargo. However, the design of the claimed device differs in that it has rigidly fixed from the outer ends of the unloading bridges of counterweights, which are at the same time a barrier fence, and also in that the rotation of the plates is performed due to the fact that the bridges are movably fixed through the axis of rotation to the supports with sides of the receiving hole. Unlike the shields, which are attached to the tracks (beams) through hinges on their lower side, the unloading bridges in the claimed invention are made in the form of plates, which are hinged to the upper part of the support beam. Due to this design feature, another system with unloading bridges can absorb more dynamically uneven loads, including from impacts of large pieces of rock in the continuous process of overloading the rock.

In addition, the proposed design ensures the minimum width of the transshipment point. In the opposite device, the rotation of the shields occurs due to the action of the hinge-lever mechanism, due to the parameters of which the width of the transshipment point will increase.

Thus, due to the formation of a new system of connections of known elements, namely bearing supports, on which the unloading bridges movably fixed through the axis of rotation rest and the counterweights rigidly attached to them at the opposite ends, which also serve as barrier fences, a non-obvious result is achieved, which consists in the ability to control continuous processes of unloading rock into the bunker, regardless of their volume and composition due to the simplicity of the design and operation of the device elements, as well as ensuring the minimum spatial parameters of the transshipment point and the minimum time of the unloading cycle.

**Results and discussion.** The most important criteria of constructing the transshipment points on open-cast mine deep horizon is minimum amount of mining capital works, the least overburden rock extraction. Other criteria, such as cost-effectiveness and environmental friendliness of transport scheme, are important, but they correlate with above-mention criteria, part of which in overall positive effect is about 92 % [17]. The correlation lies in the direct relationship between the volume of capital mining work with the cost of extracting minerals and the amount of disturbed land. That is why substantiating rock unloading device, taking into account the criteria of mining capital works is sufficient.

The construction of new transshipment points, due to their significant dimensions in plan, is connected with additional spacing of the sides of the pit. This issue becomes especially acute in the conditions of

mines with a depth of more than 300–400 m. Thus, the minimum width of the ledge platform on which the transshipment point is located is:

$$B_1 = p + b + 2u + 2a + 3R + x + c, \text{ m} \quad (1)$$

where:  $p$  – width of the prism of possible landslide, m (3–5 m);

$b$  – width of the safety embankment, m (1.5–3 m);

$y$  – road shoulder width (1–1.5 m), m;

$a$  – width of the truck, m (3.8–9.7 m);

$R$  – turning radius of the truck, m (8.7–19.8 m);

$x$  – safe distance between bodies of oncoming trucks, m (2–3 m);

$c$  – safe distance between the bunker and the lower edge of the ledge, m (5 m).

Thus, the width of the ledge platform during a dead-end turn for the unloading of trucks is 47.2–97.8 m. However, when the trucks pass through the bunker, the width of the ledge platform will be significantly reduced and will be 24–48.5 m. Its value is calculated according to the formula:

$$B_2 = p + b + 2 + R_n + , \text{ m.} \quad (2)$$

When constructing a transshipment point with through-passage of trucks above the bunker, the volume of rocks that cannot be removed should be determined by the formula [18]:

$$V_E = \frac{1}{6} H^2 (l + 2L) (\text{ctg}\alpha_1 - \text{ctg}\alpha_2) \text{ m}^3, \quad (3)$$

where:  $H$  – the height of the side of the mine, m;

$l, L$  – the width of the side of the mine at the bottom and top, m;

$\alpha_1, \alpha_2$  – angles of slopes of the side of the pit when unloading trucks with a dead-end turn and through passage over the bunker, respectively, degree.

$$\cot \alpha_1 = \frac{\sum P + B_1}{H}, \quad \cot \alpha_2 = \frac{\sum P + B_2}{H} \quad (4)$$

where  $\sum P$  – side slope projection, m.

By substituting the expressions (4) into the formula (3), we get:

$$V_E = \frac{1}{6} H (l + 2L) (B_1 - B_2) \quad (5)$$

Let's consider the formulas (1) and (2):

$$V_E = \frac{1}{6} H (l + 2L) (a + 2R + x) \quad (6)$$

Thus, by constructing a transshipment point with through-passage of trucks above the bunker at a depth of 300 m, it is possible to reduce the volume of rock extraction by 2.7–5.7 million  $\text{m}^3$ , at a depth of 400 m by 3.5–7.5 million  $\text{m}^3$ . It is known that extraction of 1  $\text{m}^3$  of rock costs approx 4 USD [19]. Then, from the point of view of extracting rocks, the savings from the implementation of the proposed solution will amount to 10–30 million USD [20].

To justify the effectiveness of the proposed design, the economic effect was calculated for the conditions of several iron ore open-cast mines in Kazakhstan (Table 1). During the calculations, the following parameters were taken into account: width of the pit at the top and bottom, design depth of the pit, load capacity, turning radius and width of trucks, as well as the cost of extracting 1  $\text{m}^3$  of rock. Since the load capacity, turning radius and width of trucks are related to a specific truck model, it is proposed to take the load capacity as a variable, as a characteristic technological parameter of a separate truck model.

Figure 5 shows the graphs of the dependence of the total cost savings on the development of rock for the construction of a transshipment point with a through passage in comparison with the dead-end unloading of trucks on their carrying capacity on the example of mines in Kazakhstan.

Graphs represent increasing polynomial functions that exist only in the first coordinate quarter. The graphs do not cross the abscissa and ordinate axes, and the function does not exist in the second and third coordinate quarters, since the carrying capacity of trucks is a positive value. The function does not exist in the fourth coordinate quarter, as the proposed design has smaller spatial parameters and a smaller volume of mining capital works.

The resulting dependencies allow us to assert the effectiveness of using a transshipment point with a through passage for heavy-duty trucks at significant depths in compressed conditions due to the reduction of the volume of mining capital works.

Table 1 – Parameters of surface mining of iron ores in Kazakhstan

Parameter name	Kacharsky mine	Sarbaysky mine	South Sarbai mine	Sokolovsky mine	Kurzunkul mine
Mark of the mine bottom, m	-570	-480	-340	-380	-215
Mine depth Hd, m	764	680	530	570	405
Geological reserves of ore Vm,g, mln t	803,4	87,6	146,4	66,7	73
Iron content in ore: in deposit, % at factory, %	39,13 38,18	38,96 35,5	42,12 37,69	34,8 28,06	44,52 35,96
Exploitable ore reserves Vm, mln t	824,1	91,7	164,8	69,4	95,4
The volume of overburden in mine (incl. rocks) Vr, mln m <sup>3</sup>	956,3 (574,1)	74,3 (62,5)	504,7 (208,8)	34,8 (34,8)	113,1
Average stripping ratio ka, m <sup>3</sup> /t	1,16	0,81	3,45	0,5	1,19
Sizes of the mine on the surface: – width B, m; – length L, m	2900 3000	2500 3600	1900 3300	2000 3400	1500 1500
Sizes of the mine on the bottom: – width bd, m; – length ld, m	175 430	80 1000	100 175	70 200	150 200

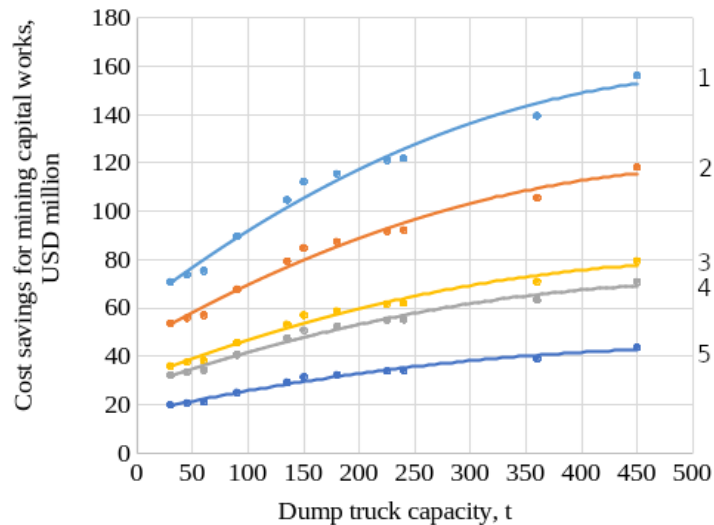

Figure 5 – Graphs of the dependence of the total cost savings on the extraction of overburden rocks on the loading capacity of trucks when constructing a transshipment point with a through passage compared to the dead-end unloading of trucks on the example of mines in Kazakhstan:

1 – Kacharsky mine; 2 – Sarbaysky mine; 3 – Sokolovsky mine; 4 – South Sarbai mine; 5 – Kurzunkul mine



**Conclusions.** The use of a new design of the transshipment point with the possibility of through-passage of trucks when unloading them into the receiving bunker of the conveyor elevator is substantiated, which allows to reduce the costs of mining and capital works.

The obtained dependences of the reduction of costs for mining and capital works for deep open-cast mines of Kazakhstan during the construction of a transshipment point of the combined automobile-conveyor transport of the proposed design on the

load capacity of trucks, which allow us to assert the effectiveness of the use of a transshipment point with through-passing of heavy trucks during their unloading at the expense of reduction of the volume of mining and capital works.

Currently, the degree of readiness of the developed device is a working drawing.

**Financing:** *The article was prepared under the Grant funding project of the Ministry of Science and Higher Education of the Republic of Kazakhstan No. AR14869083.*

### References

1. Dryzhenko A. Y. Vidkryti hirnychi roboty: pidruchnyk // Natsionalnyi hirnychiy universytet. -2014. – 590 s. [in Ukraine]
2. Pat. 880931 Ustroistvo dlya razgruzki avtosamosvalov v bunker/ Pavlov A.Y., Rogach M.S., Klubnichkin Y.K., Ivanova Y.Y., Propletin A.P. -№ 2879141/27-11; zayavl. 30.01.80; opubl. 15.11.81, Byul. № 42. [in Russian]
3. Pat. 713801 Ustroistvo dlya razgruzki avtosamosvalov nad bunkerom / Markov N. G., Smetanin V. G., Istomin L. V., Dereshevatiy O. Y. -№ 2572759/27-11; zayavl. 10.01.78; opubl. 05.02.80, Byul. № 5. [in Russian]
4. Pat. 135021, Ustroistvo dlya razgruzki samosvalov v bunker / Pashkin B. M., Markozyan P. D. -№653221/27; zayavl. 04.02.1960; opubl. 1961, Byul. № 1. [in Russian]
5. Pat. 988726, Ustroistvo dlya razgruzki avtosamosvalov v bunker / Anikin N.N., Kuprii V.T., Chaikovskii A.I. -№3329001/27-11; zayavl. 10.08.81; opubl. 15.01.83, Byul. № 2. [in Russian]
6. Pat. 718346 Ustroistvo dlya razgruzki avtosamosvalov v bunker / Tartakovskii B.N., Krimskii V.I., Andryushchenko A.V., Lashko V.T., Anikin N.N. zayavl. 31.07.78; opubl. 28.02.80, Byul. № 8. [in Russian]
7. Pat. 132123 Ustroistvo dlya razgruzki samosvalov v bunker / Pashkin B.M., Popov A.N. -648928/27; zayavl. 29.12.1959; opubl. 1960, Byul. № 18. [in Russian]
8. Pat. 933589 Ustroistvo dlya razgruzki avtosamosvalov v bunker / Anikin N. N., Chaikovskii A. I., Parshkin E. M. -№3008935/27-11; zayavl. 26.11.80; opubl. 10.06.82, Byul. № 21. [in Russian]
9. Pat. 1090649 Ustroistvo dlya razgruzki samosvalov / Drizhenko A.Yu., Shmitko A.I., Simonenko V.I., Kritov A.Y., Birin I.S.; zayavitel' Gosudarstvennyi institut «Yuzhgiproruda». -№3541875/27-11; zayavl. 12.01.83; opubl. 07.05.84, Byul. №17. [in Russian]
10. Pat. No. 1057393 Ustroistvo dlya razgruzki avtosamosvalov / Makashov V.N., Korbinskii G.M., Drizhenko A.Y., Grinberg E.M. -№3496130/27-11; zayavl. 27.09.82; opubl. 30.11.83, Byul. № 5.
11. Pat. 606796 Most dlya nadbunkernoï razgruzki avtosamosvalov / Menshikov B.A., Sisin A.G. -№2363682/22-11; zayavl. 24.05.76; opubl. 15.05.78, Byul. №18. [in Russian]
12. Pat. 800077, Ustroistvo dlya nadbunkernoï razgruzki avtosamosvalov / Budanov V.Y., Koryakin A.I., Lokhanov B.N. -№2777889/27-11; zayavl. 27.04.79; opubl. 30.01.81, Byul. № 4. [in Russian]
13. Pat. 34570 Ustroistvo dlya peregruzki skalnikh porod s avtotransporta na konveiernii podemnik / Moldabayev S.K., Kuzmenko S.V., Kalyuzhnii Y.S., Drizhenko A.Y., Adamchuk A.A. -№ 2019/0143.1; zayavl. 21.02.2019; opubl. 11.09.2020. [in Russian]
14. Pat. 119491 Prystrii dlia rozvantazhennia porid iz avtosamoskydiv u bunker / Dryzhenko A.Y., Adamchuk A.A., Shustov O.O., Moldabaiev S.K., Nikiforova N.A. 2019. [in Russian]
15. Pat. 120157 Priemnoe ustroistvo dlya uglya i drugikh sipuchikh i kuskovikh materialov / Shvernik A. M., Shlikhter L.V., Tunkel N.R. -№603176/27; zayavl. 30.06.1958; opubl. 05.02.80, Byul. № 10. [in Russian]
16. Pat. 147533, Most dlya razgruzki sipuchikh materialov v bunkeri i rudospuski / Anistratov Y.I., Rzhhevskii V.V., Karetnikov V.N., Lyapin L.A. -№732907/27; zayavl. 01.06.1961; opubl. 1962, Byul. № 10. [in Russian]

- 
17. Adamchuk A. A., Shustov O. O. Systemnyi pidkhid do vyboru novykh zasobiv transportu dlia roboty na hlybokykh kar'ierakh // Zbirnyk Naukovykh Prats Natsionalnoho Hirnychoho Universytetu. -2018. -№54. -S. 8-18. –URL: <http://ir.nmu.org.ua/handle/123456789/152728> [in Ukraine]
18. Adamchuk A. A. Issledovanie parametrov dorabotki glubokikh karerov otkritim sposobom. //Zbirnyk Naukovykh Prats Natsionalnoho Hirnychoho Universytetu (Collection of Scientific Papers of The National Technical University). -2017. - № 50. - S. 10–17. [in Ukraine]
19. Babets Y. K., Melnykova I. Y., Hrebenuk S. Y., Lobov S. P. Doslidzhennia tekhniko-ekonomichnykh pokaznykiv hirnychodobuvnykh pidpriemstv Ukrainy ta efektyvnosti yikh roboty v umovakh zminnoi kon'iunktury svitovoho rynku zalizorudnoi syrovyny: monograph / vyd. R.A. Kozlov //Study of technical and economic indicators of mining enterprises of Ukraine and their efficiency in the conditions of changing the global market of iron ore raw materials): monohrafiia. -2015. -391 s. [in Ukraine]
20. Adamchuk A. A. Obgruntuvannia skhemy avtomobilno-konveiernoho transportu iz naskriznym proizdom avtosamoskydiv pry rozvantazhenni. (Justification of the auto-conveyor transport scheme with truck through passing while unloading) // Fiziko-Tekhnicheskie Problemi Gornogo Proizvodstva: Sb. Nauchn. Tr. (Physical-technical problems of mining: Collection of scientific works) – 2021. - № 23. - S.200-215. DOI 10.37101/ftpgp23.01.013 [in Ukraine]

#### ***Information about authors***

Moldabayev S.- Doctor of Technical sciences, Professor, Satbayev University, Almaty, Kazakhstan, e-mail: [s.moldabayev@satbayev.university](mailto:s.moldabayev@satbayev.university);

Adamchuk A. – Candidate of Engineering Sciences, Dnipro University of Technology, Dnipro, Ukraine, e-mail: [Adamchuk.A.A@nmu.one](mailto:Adamchuk.A.A@nmu.one);

Sarybayev N. – PhD, Satbayev University, Almaty, Kazakhstan, e-mail: [n.sarybayev@satbayev.university](mailto:n.sarybayev@satbayev.university);

Moldabayev A.- Master's degree student, Satbayev University, Almaty, Kazakhstan, e-mail: [asangiz.moldabaev@stud.satbayev.university](mailto:asangiz.moldabaev@stud.satbayev.university);

Nurmanova A. – PhD student, Satbayev University, Almaty, Kazakhstan, e-mail: [a.nurmanova@satbayev.university](mailto:a.nurmanova@satbayev.university)

#### ***Сведения об авторах***

Молдабаев С. – доктор технических наук, профессор, Сатпаев университет, Алматы, Казахстан, e-mail: [s.moldabayev@satbayev.university](mailto:s.moldabayev@satbayev.university);

Адамчук А. – кандидат технических наук, Национальный технический университет «Днепропетровская политехника», Днепр, Украина, e-mail: [Adamchuk.A.A@nmu.one](mailto:Adamchuk.A.A@nmu.one);

Сарыбаев Н. – PhD, Сатпаев университет, e-mail: [n.sarybayev@satbayev.university](mailto:n.sarybayev@satbayev.university);

Молдабаев А.-студент магистратуры, Сатпаев университет, Алматы, Казахстан, e-mail: [asangiz.moldabaev@stud.satbayev.university](mailto:asangiz.moldabaev@stud.satbayev.university);

Нурманова А.- студент PhD, Сатпаев университет, Алматы, Казахстан, e-mail: [a.nurmanova@satbayev.university](mailto:a.nurmanova@satbayev.university)/